

FFOB-168

AT A GLANCE

Capacity:	2 x Round 10 Amp
Autoswitched GPOs & 3 x Single Data	
Lid Size:	145 x 145 x 12mm
Box Size:	126 x 125 x 95mm
Recess Size:	165mm Diameter x 117mm Deep
Ratings:	IP54 Pending



IP54 RATING PENDING

Features

- Stainless Steel Lid
- Rubber Matting to provide Water and Dust Resistant seal
- Stainless Steel Frame
- Temporary Lid - secure to body during concrete pour to prevent ingress of slurry
- Steel Box Body - 126 x 125 x 95mm nom. deep. Has 6 x combination 25mm/32mm conduit knockouts - 4 on outside of box and 2 on bottom
- Outlet Bracket to Suit 2 x 10Amp Round Autoswitched GPO's
- Outlet Bracket to Suit 3 x Single Data Outlet Clips
- Block-out in concrete slab - 145 x 146 x 117mm OR 165mm Diameter x 117mm Core nom.

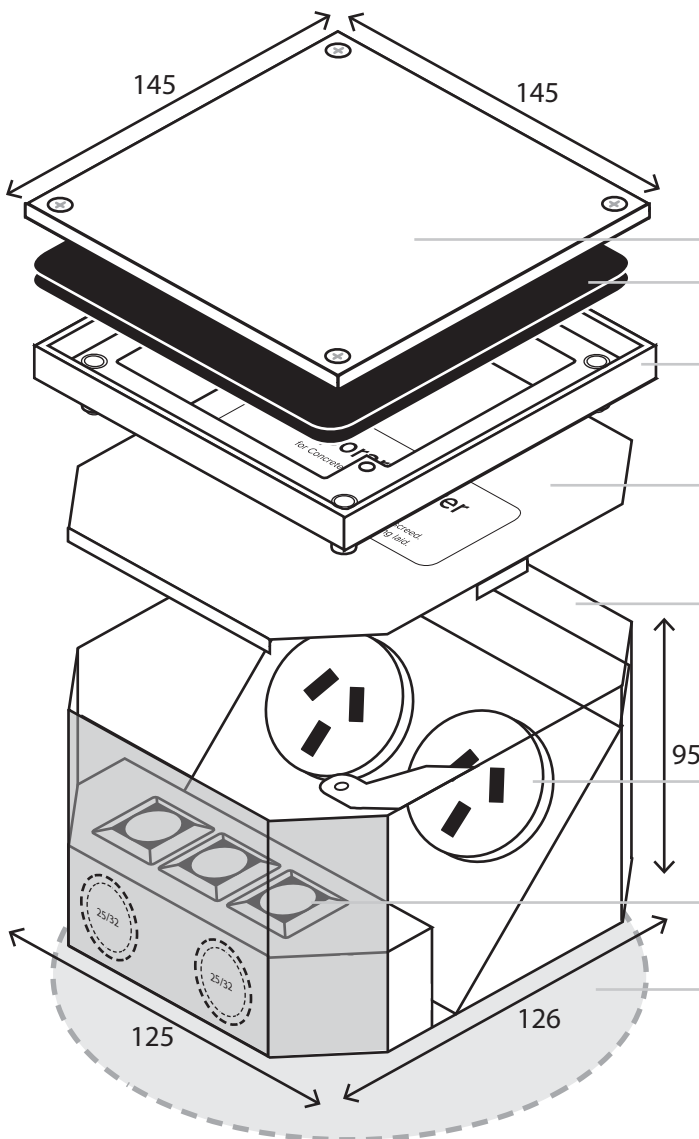
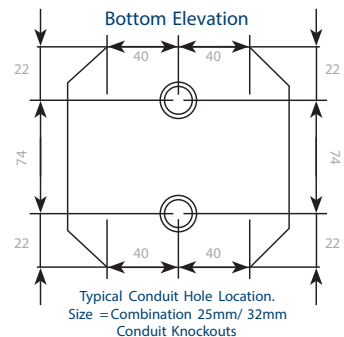
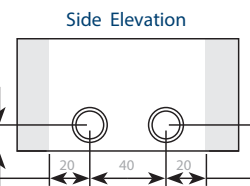
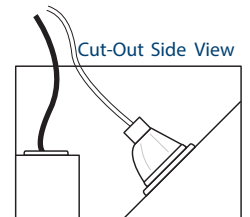
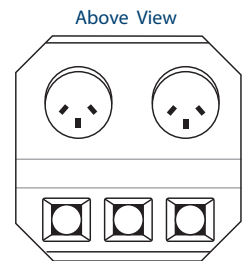

All Dimensions quoted are nominal only. Drawings, images and diagrams are for illustrative purposes only and are not to scale. Product details and dimensions are subject to change without notice. This product is intended for use with fixed wiring only and must be installed by a licensed electrical mechanic in accordance with AS3000, SAA Wiring Rules and A.C.A Requirements



Step 1: Prepare Area for Installation

- Secure Steel Box Body housing (125x126x95mm) to structural slab (recommended) or within preformed recess/blockout (145x146x117mm OR 165mm Diameter x 117mm Core Nominal). Ensure Box Body is positioned so that Floor Box Lid finishes flush and level with final floor finish height and is secured to prevent 'dipping' or 'floating' within screed
- Positioning and securing the Box Body accurately will prevent operation/installation problems at later stages
- Connect conduits to Steel Box Body at desired location(s) and cover opening in box body using the Temporary Cover to prevent screed entering the box. Cover screw heads using duct tape, to allow screw removal after screed hardens.

Important: Seal any gaps around conduit entries with sealant or duct tape prior to screeding it

Step 2: Floor box Lid Installation

- Remove Temporary Cover from Steel Box Body
- Lay and trim floor surface (carpet, vinyl, tiles etc) to the size of the floor box STA INLess steel lid for FFOB-168
- Terminate outlets as required (as per AS3000) fixing them to the mounting bracket supplied and ensuring all metal components maintain earth continuity
- Fit Stainless Steel Lid & Frame using M8 countersunk screws supplied and test the operation of the unit.

Important: In order to ensure IP54 Rating, the underside of the floor box frame must be sealed with an appropriate sealing compound when being fitted to the floor. The floor box lid and rubber gasket must be free from debris when being closed in order to maintain correct seal.